

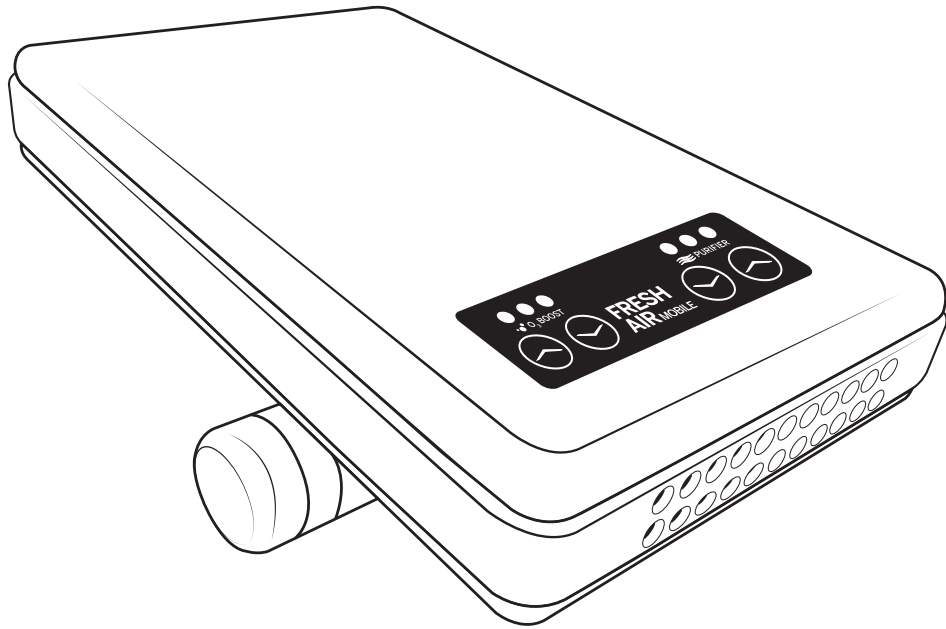

**FRESH
AIR** Mobile™



Portable Electronic Purifier

Read manual carefully for proper use and optimal operation.

General Information

Product Overview

Congratulations on your purchase! Your new Vollara® FreshAir Mobile is a portable air purifier that combines complementary technologies, including PCO–A (Photocatalytic Oxidation – Advanced) Technology and Ozone (O₃) to provide air purification in small indoor and personal spaces. Please read and follow all safety warnings and instructions outlined in this owner’s manual, before operation or maintenance.

Contents

Product Overview	2
Specifications.....	2
Storage & Disposal	2
Important Safety Instructions.....	3
Parts & Accessories	4
Directions for Use	5
Mounting the Base	6
Adjusting the Wire Stand.....	6
Wire Stand Positions	6
Power Adapters	7
12 Volt DC Car Adapter	7
Portability	8
Maintenance.....	8
Cleaning the Unit.....	8
Removing the PCO–A Assembly.....	9
Replacing the PCO–A Assembly	10
Troubleshooting.....	11
Replacement Parts	12
Warranty Information.....	13
FCC Declaration & Responsible Party	14

Specifications

Vollara FreshAir Mobile _____

- Sales Number: 9940059
- Model Number: A1018B

DOES NOT meet California requirements and cannot be shipped to California or Canada.

Technology _____

- PCO–A (Photocatalytic Oxidation – Advanced) Technology - (1) 2.5" Assembly
- Ozone (O₃)

Electrical _____

- 12 Volts DC; 50/60 Hz; 1.0 Amp
- Power: 10.7 Watts Max

Mechanical _____

- Fuse: 2 Amp Buss type (adapter only)
- 3-speed fan

Weight & Dimensions _____

- 8 oz (226.8 g)
- 1.0" H x 3.6" W x 6.0" D (w/o base)
(2.5 cm x 9.1 cm x 15.2 cm)

Operating Temperature _____

- 45°F – 100°F (7.2 °C - 37.8 °C)

Coverage _____

- Up to 50 sq. ft. with uniform air diffusion; for single occupant use.¹

Warranty _____

- Limited one (1) year warranty
- Terms and conditions may apply

We reserve the right to change or modify any specification without notice.

¹ Dependent on occupancy of the space

Fill In and Save

Record information regarding your new Vollara FreshAir Mobile here. Retain for future reference.

Model No. _____ Serial No. _____ Date of Purchase _____

Name: _____ Phone No. _____

Address: _____

Vollara Independent Business Owner: _____

Storage and Disposal

Do not dispose of this product as household waste. Electrical waste and electronic products should be appropriately recycled as required by practices established by your local authority.



If you have any questions concerning this product, please contact your Vollara Independent Business Owner or Customer Service at 800.989.2299 or email customerservice@vollara.com

Important Safety Instructions



- UV Bulb in operation: Direct exposure to the internal UV light may cause eye damage.
- Do not operate the Vollara® FreshAir Mobile unless the case is completely and correctly assembled; failure to comply may result in serious eye damage
- Do not operate unit near heat sources, open flame, or combustible vapors or gases
- The unit must be disconnected from its power source before servicing, and should not have the power reconnected unless the case is correctly and completely reassembled



- Use O₃ Boost in accordance with directions found in this manual only
- Not for use on 12 volt positive ground or 24 volt vehicles; doing so may damage the product

Read this manual in its entirety before using your Vollara FreshAir Mobile
Keep out of the reach of children.

- Disconnect Power Cord before servicing
- **DO NOT** immerse in water or other liquids
- **DO NOT** touch the control panel or plug with a wet hand
- **DO NOT** insert or allow foreign objects to enter any ventilation or exhaust opening as this may cause an electric shock or fire, or damage the air cleaner
- To prevent a possible fire, **DO NOT** block the air intakes or exhaust in any manner; **DO NOT** use on soft surfaces, where openings may become blocked
- To disconnect air cleaner, turn controls to **OFF**, then remove plug from outlet; pull firmly on the plug, **DO NOT** unplug by pulling on the cord
- Always unplug the unit before moving or cleaning, or whenever the air cleaner is not in use
- **DO NOT** use outdoors or on wet surfaces
- **DO NOT** attempt to repair or adjust any electrical or mechanical functions on this unit, doing so will void your warranty
- Connect to properly grounded outlets only
- To reduce the risk of electrical shock, do not change the plug in any way

Save these instructions.

Parts & Accessories

- A. Wire Stand (9950153)
- B. Base (9950154)
- C. Knob/Clamp Pack (2) (9950155)
- D. 12 Volt DC Adapter (9950157)
- E. 2.0 AMP Fuse (9950162)
- F. AC ADAPTER (9950158)
- G. PCO-A Assembly Service Kit (9950209)

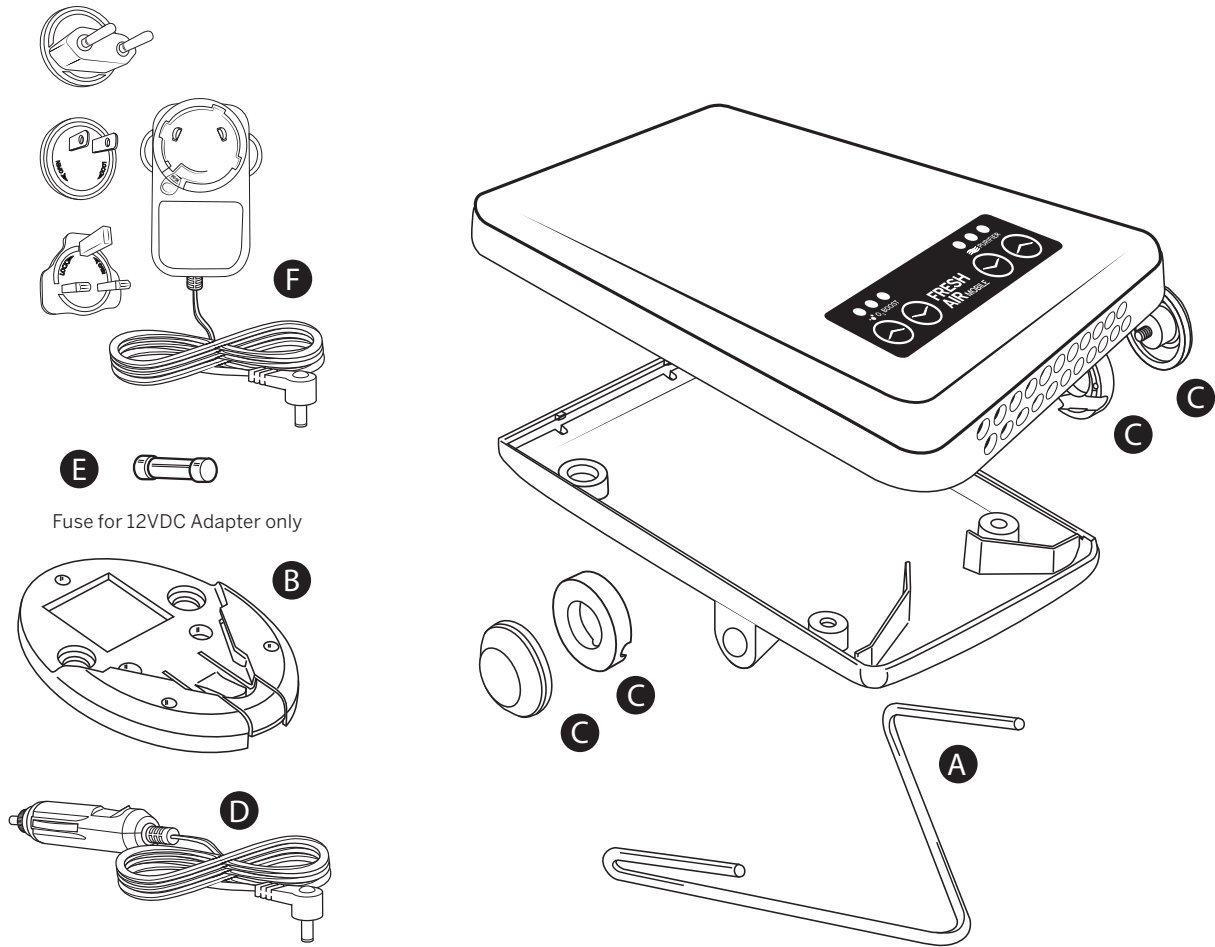

Fuse for 12VDC Adapter only

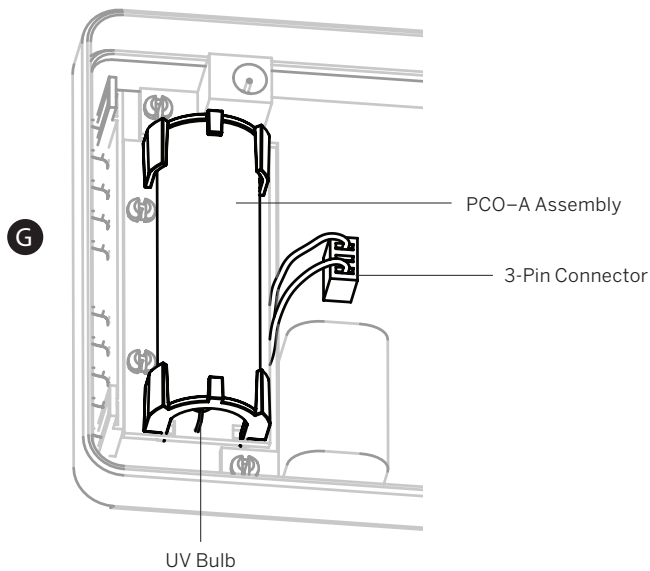

Directions for Use



- When running continuously for extended periods of time, it may be necessary to clean the unit more frequently than normal. Remove any dust from the outside as well as the inside the unit to maintain optimal performance. A lack of cleaning/maintenance may lead to product performance or life issues
- **DO NOT** place unit where it may be exposed to temperatures above 100°F as doing so may cause the plastic to deform

1. If desired, mount the base in an appropriate location (see page 6).
2. Adjust the wire stand (see page 6).
3. Plug in either the 12 Volt DC Car Adapter or the AC Adapter into the Fresh Air Mobile.
4. The Vollara® FreshAir Mobile unit will turn on when power is supplied to the unit.
5. Adjust the Purifier by pressing the **PURIFIER UP** and **PURIFIER DOWN** buttons. When the unit is ON, all the LED lights will illuminate.
6. Set the O₃ Boost by pressing the **O₃ BOOST UP** and **O₃ BOOST DOWN** buttons. See the Settings chart (below) for proper adjustments. When the O₃ Boost is set to off, the LEDs will also be off; the Purifier LED(s) will remain on.
DO NOT exceed recommended settings.

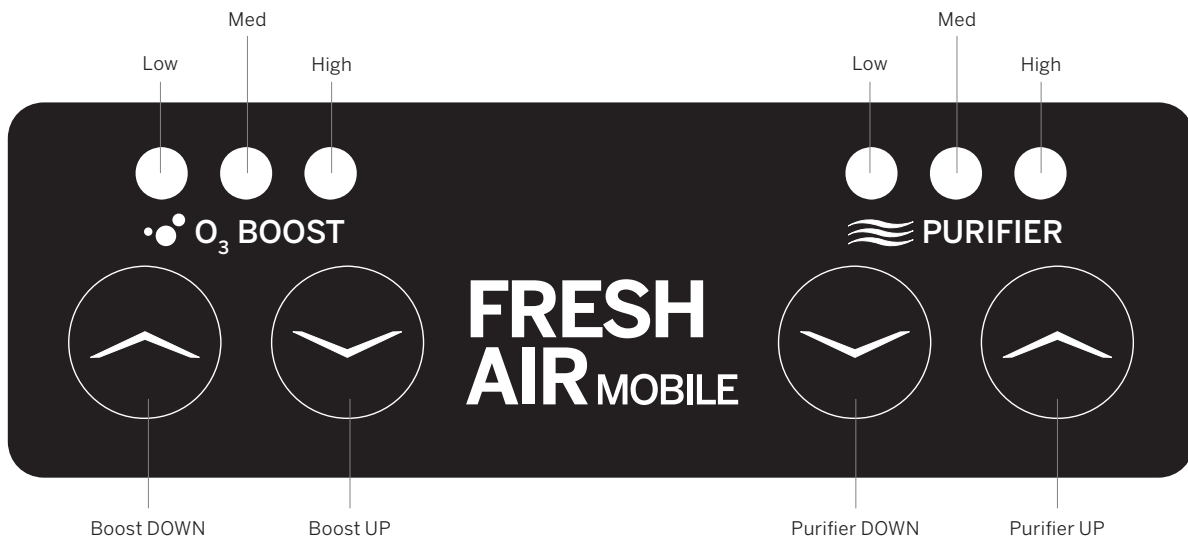

LEDS	SETTING	COVERAGE
● ● ☀	Low:	Compact Car, Pickup
● ☀ ☀	Med:	Large Sedan, SUV, or Semi-Cab
☀ ☀ ☀	High:	RV/Motor Home or Houseboat
● ● ●	OFF:	Purifier off: ionization & fan may continue operating if desired.

Mounting the Base

The base for the Vollara® FreshAir Mobile can be mounted using the included suction cups, Velcro, or screws, depending on preference. When using suction cups or Velcro, be sure the surface is smooth and clean. Dirt, grease, protectants, and other substances will affect performance and holding ability.

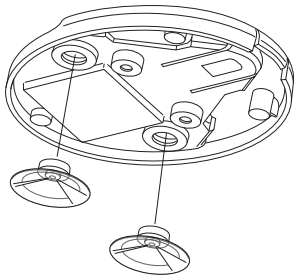

- Attach suction cups by pressing and twisting into the base, or...

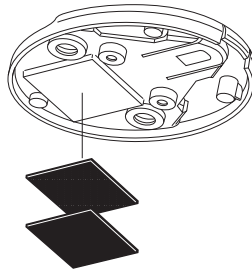

- Peel and stick one part of the Velcro to the base, then attach the other to a clean, dry surface, or...

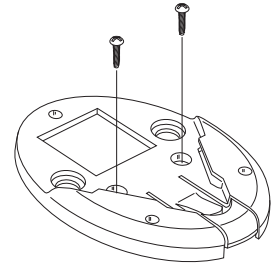

- Screws may be used for extra security and where the other methods are not appropriate.

Adjusting the Wire Stand

The wire stand on the Vollara FreshAir Mobile allows for quick release from the base, provides a stand or hanger for the unit independent of the base, and allows the unit to either stand or hang from the base depending on how the base is mounted.

To adjust the wire stand, loosen the two knobs on the sides of the unit approximately 1/2 turn. The unit may then be tilted up or down to adjust the angle or moved on the wire stand to change the height. You can also remove and change the position of the wire stand to accommodate several different mounting methods. To reinstall, simply align the two clamp collars and insert the wire stand. Once the unit is adjusted, tighten both knobs to hold it in place.

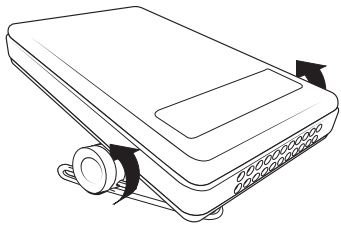

THEN

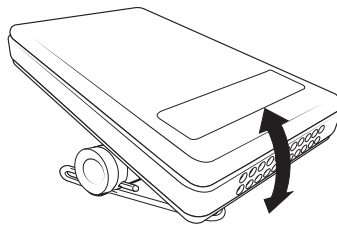

OR

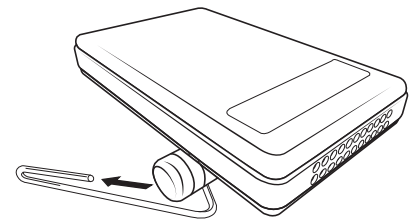

Wire Stand Positions

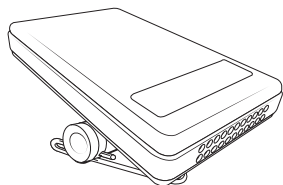

- Sitting on a flat surface with or without the base
- Hanging over an edge pointing down (laundry hamper, garbage can, etc.)

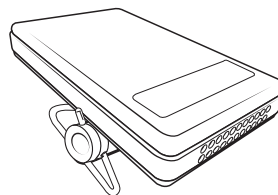

- Sitting on a flat surface without the base
- On a vertical surface with the base (wall mount, window, etc.)
- Hanging over an edge pointing up (seat pocket in car)

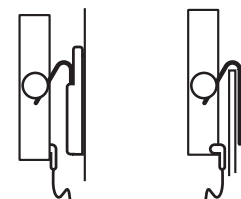
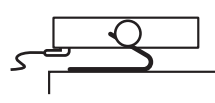
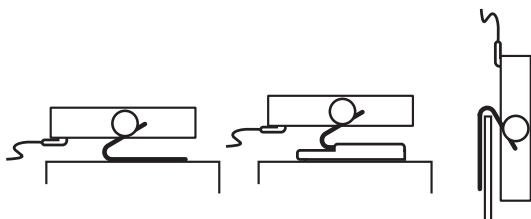

NOTE: Unit can be used without attaching the base or wire stand.

Power Adapters



Not for use on 12 Volt positive ground or 24 Volt vehicles. Doing so may damage the product.

Vollara® FreshAir Mobile comes with both a 12 Volt DC car adapter and a 100 - 240 volt 50/60 Hz AC adapter with interchangeable plugs.

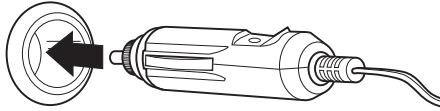

- Insert the car adapter into an appropriate 12 Volt automotive type power outlet.

12 VOLT DC ADAPTER FUSE



To change the car adapter fuse, unscrew and remove the front of the adapter. Replace with the same type and rating only: 2 amp Buss type fuse (service part #9950162).

NOTE: For proper operation using the 12 Volt car adapter, make sure the fit in the power outlet is snug. A loose fit may cause issues in unit operation or blown fuses.

OR

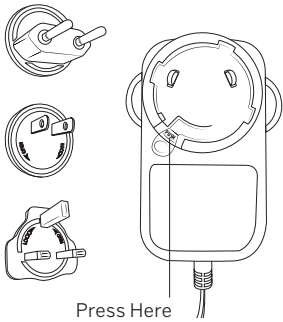

- Select and install the proper international plug into the AC adapter. Insert correctly assembled adapter into a standard electrical outlet.

NOTE: When installing one of the interchangeable plugs, be sure to twist and lock it into place. When removing a plug, press the raised tab to release, then turn the plug out the top.

THEN

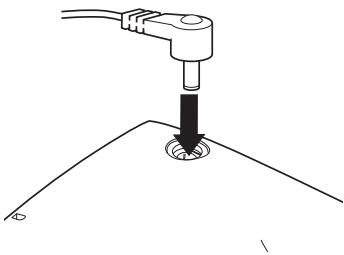

- Insert the small adapter plug into the opening located underneath at the rear of the unit.

12 Volt DC Car Adapter

Vollara® FreshAir Mobile has an operating voltage range of 11 Volts DC to 14.6 Volts DC. If the voltage coming into the unit is too high, the unit may blow the 12 Volt DC adapter fuse. This type of problem usually indicates something is wrong with a vehicle's electrical system. If the unit shuts down while using the 12 Volt DC automotive adapter and you are unsure of the cause, check the adapter fuse. If the fuse is not blown, test the unit using the supplied AC adapter. Once the voltage problem (drained car battery, electrical system problem, etc.) is corrected by a qualified service person, you will be able to resume using your Vollara FreshAir Mobile with the 12 Volt DC adapter.

Portability

Depending on how it is mounted, your Vollara® FreshAir Mobile can be ready to take with you in just a few seconds.

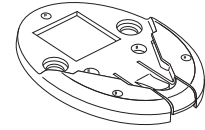
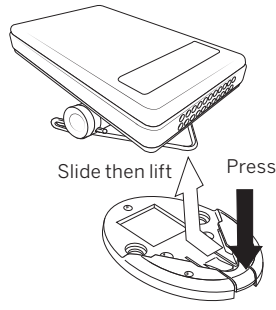
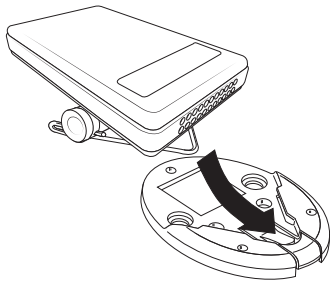

- Once the unit is assembled and the base mounted, simply snap the wire stand into the base. The latch at the front of the base should snap into place, locking in the stand and unit.
- To remove the unit from an attached base, press down on the front latch and slide the unit back, then up.
- For added convenience, mount extra bases where you use your unit most. See your Vollara Independent Business Owner for more information.

NOTE: If you prefer to remove the base and unit together, mount the base with Velcro or suction cups to a clean, dry surface.

Maintenance



- Use genuine Vollara Replacement parts only; Parts from anyone other than an authorized Vollara Representative may damage your unit and void your warranty
- For optimal performance, we recommend the replacement of the PCO–A Assembly once every 12 months even if the UV bulb appears to be operating normally
- The unit must be disconnected from its power source before servicing, and should not have the power reconnected unless the case is correctly and completely reassembled.

A PCO–A Assembly Service Kit (9950209) is available for your Vollara FreshAir Mobile. The kit contains a PCO–A Assembly and Purification Plate. **For optimum performance, we recommend periodically cleaning and replacing these components annually.** Refer to the following sections for details on maintaining your unit properly and see page 12 to order replacement parts.

Cleaning the Unit

Depending on conditions, your Vollara FreshAir Mobile will require periodic cleaning of certain internal components every one to three months.

PCO–A Assembly

Clean the Assembly by gently removing dust with a small, soft brush.

Purification Plate

The top area of the Purification Plate can be cleaned with ammonia or alcohol and a cotton swab. Do not use water. Allow to dry thoroughly.

Case

Clean the exterior of your Vollara Fresh Air Mobile with a soft cloth dampened (not wet) with water. Do not use harsh chemicals or solvents.

Fan / Interior of Unit

The interior and fan may be cleared of dust using canned air suitable for electronics.

Replacing the PCO–A Assembly



The Vollara® FreshAir Mobile unit must be turned off and disconnected from power before servicing, and should not be powered back on until the case is correctly and completely reassembled



Use genuine Vollara Replacement parts only. Parts from anyone other than an authorized Vollara Representative may damage your unit and void your warranty

For maintenance and replacement of PCO–A Assembly Service Kit 9950209

DISASSEMBLY

All user maintainable parts of the PCO–A Assembly Service Kit are accessed by removing the lower half of the case.

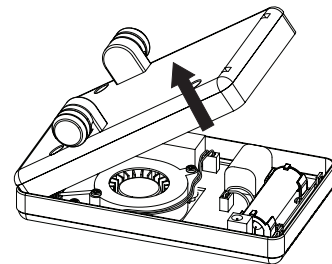
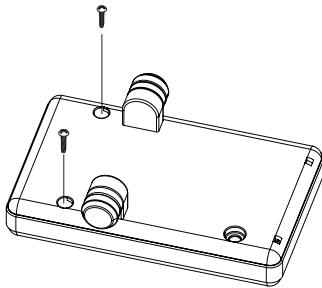

1. Turn unit over, tilt up slightly, and remove screws at the front of the unit.
2. With the front remaining tilted up, slide the lower half of the case back and up until it is free.

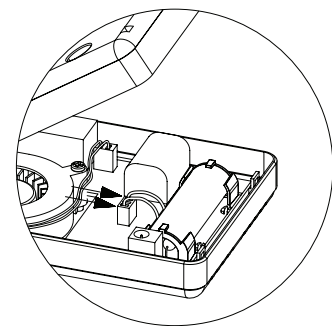
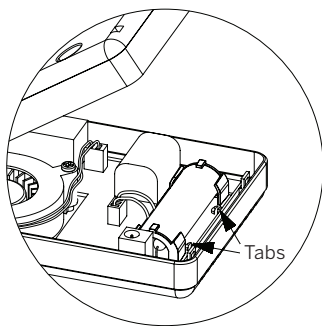

3. Lift the small circuit board holding the PCO–A Assembly from the two tabs.
4. Disconnect the leads of the PCO–A Assembly from the main circuit board.

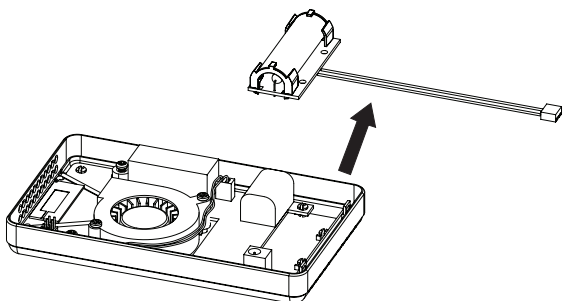

5. Remove the PCO–A Assembly from the unit.



STORAGE AND DISPOSAL

Do not dispose of this product as household waste. Electrical waste and electronic products should be appropriately recycled as required by practices established by your local authority.

Replacing the PCO–A Assembly

ASSEMBLY

Assembly is the reverse of the steps illustrated on page 9.

1. PCO–A Assembly — Do not touch with bare hands. If touched, clean the bulb with a cotton swab and a small amount of isopropyl alcohol.
2. Attach the 3-pin connector of the PCO–A Assembly to the main unit circuit board.
3. Carefully align the two holes in the PCO–A Assembly to the two tabs on the main unit.
4. Press gently to install the PCO–A Assembly.
5. Carefully replace the bottom case, being sure the pins inside the back of the bottom case fit into the two standoffs at the back of the top case.
6. Slide the bottom case forward then down, making sure the wires are completely inside the case.
7. Check for proper alignment the before installing and tightening the screws.

NOTE: Failure to correctly assemble may cause damage to the case.

8. Replace cover and two screws.

For questions on maintenance procedures, please contact your Vollara Independent Business Owner or Customer Service at 800.989.2299 or email customerservice@vollara.com

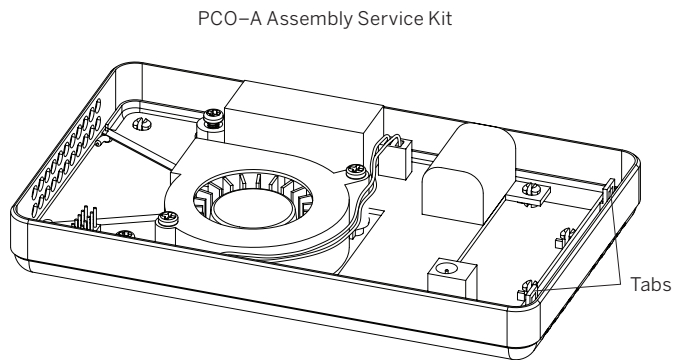
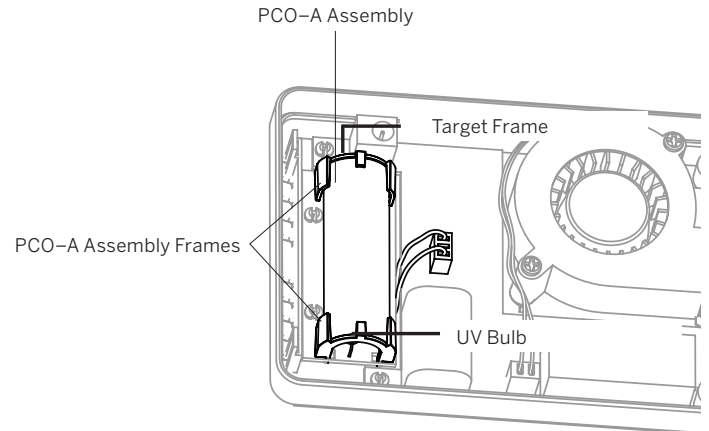
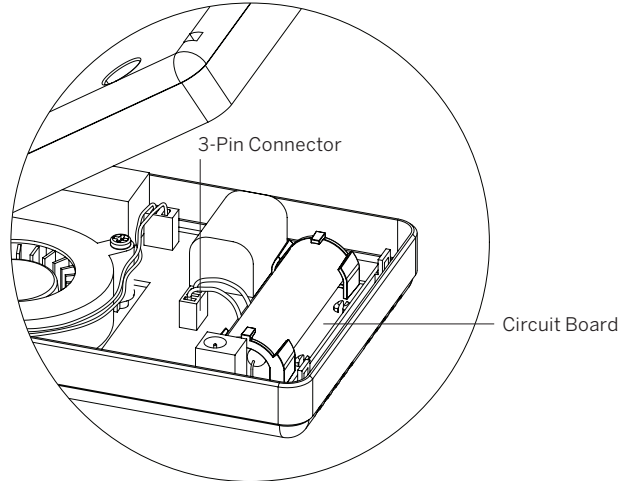

Troubleshooting



- Under no circumstances should your Vollara® FreshAir Mobile unit be operated while any part of the case is damaged, missing, or disassembled; if the case is damaged, return your unit to Vollara for repair or replacement
- Direct exposure to the internal UV light may cause eye damage

TROUBLESHOOTING — WHAT TO LOOK FOR FIRST

Unit does not operate/the O₃ Boost does not operate/all LEDs off

1. Unplug and reinsert the Adapter plug and adapter to check where the power supply is plugged in to be sure it has power.
2. If using the 12 Volt DC Car Adapter, remove the fuse by unscrewing the end of the adapter and check to see if it is blown. Replace it with the same type and rating fuse only (See Specifications on page 2). If the fuse is not blown, check the outlet for proper voltage.

UV Bulb or O₃ Boost may not be working

1. Press the **PURIFIER UP** or **PURIFIER DOWN** buttons to turn the Purifier function **ON**.
2. If checking O₃ Boost operation, press the O₃ Boost UP button to turn the O₃ Boost **ON**.
3. Remove the PCO–A Assembly, clean, and reinstall (see diagram on Page 4).
4. If cleaning and reinstalling does not correct the problem, replace the PCO–A Assembly (service kit #9950209).
5. When looking through the rear inlet vents in low light you should see a slight bluish glow. If there is no glow, replace the PCO–A Assembly (service kit #9950209).

Lack of air flow

1. Make sure the intake vents are not blocked and the front of the unit is clear.
2. Check to see if the fan is operating (if not, see above).

If your unit fails to operate properly after performing troubleshooting, please contact your Vollara Independent Business Owner or Customer Service at 800.989.2299 or email customerservice@vollara.com.

Replacement Parts

REPLACEMENT PARTS (QTY)	PART NUMBER
PCO-A Assembly Service Kit	9950209
AC ADAPTER	9950158
12 Volt DC Adapter	9950157
Wire Stand	9950153
Base	9950154
2.0 AMP Fuse	9950162
Knob/Clamp Pack (2)	9950155

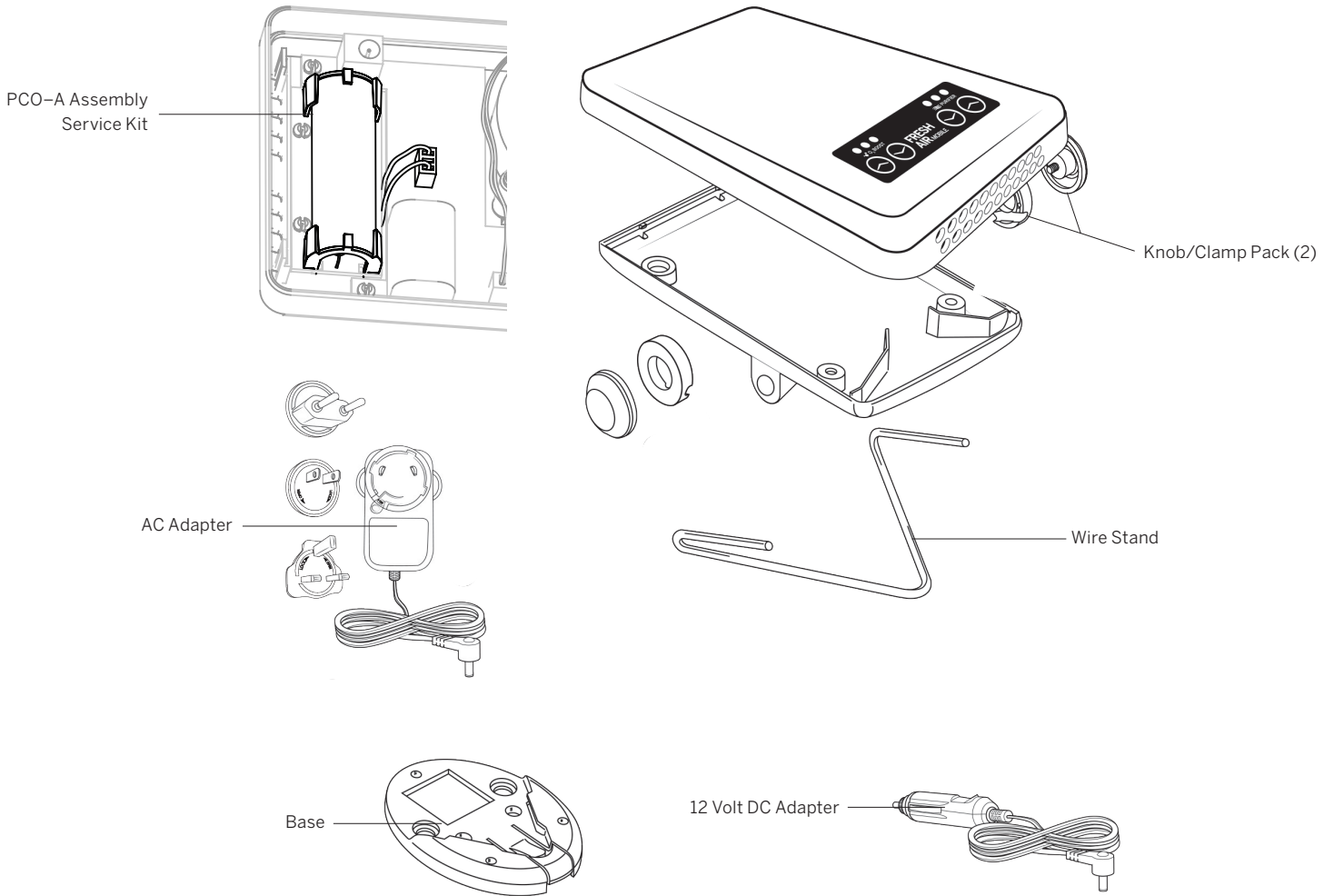

To order replacement parts, please contact your Vollara® Independent Business Owner or Customer Service for further assistance at 800.989.2299 or email customerservice@vollara.com.

Warranty Information

Limited One (1) Year Warranty

To register your Vollara® FreshAir Mobile unit, visit vollaraintl.com/vollara/warrantyregistration.aspx or Customer Service at 800.989.2299 or email customerservice@vollara.com.

Customer should not repackage and ship the Vollara FreshAir Mobile unit due to possibility of irreparable damage. For warranty service, please contact Customer Service at 800.989.2299 or email customerservice@vollara.com.

WHAT IS COVERED BY THIS WARRANTY

We warrant the Vollara FreshAir Mobile to the customer, subject to the conditions below, against defects in workmanship or material, provided that the products are returned to an authorized Vollara location within the following time periods:

- Vollara FreshAir Mobile within one (1) year of date of purchase

MAINTENANCE REQUIREMENTS

This warranty is expressly conditioned upon proper operation, cleaning and maintenance, all in accordance with the Owner's Manual. Failure to meet any of these requirements will void this warranty. Servicing of your Vollara FreshAir Mobile by parties other than an authorized Vollara Representative and/or using parts other than genuine parts will also void this warranty.

HOW TO OBTAIN WARRANTY SERVICE

Customer must register their product at vollaraintl.com/vollara/WarrantyRegistration or contact Customer Service at 800.989.2299 or email customerservice@vollara.com and provide proof of purchase within the above time periods. Vollara will repair or replace and return the product, without charge and within a reasonable period of time, subject to the conditions herein, if its examination shall disclose any part to be defective in workmanship or material. If we, in our discretion, are unable to repair the product after a reasonable number of attempts, we will provide either a refund of the purchase price or a replacement unit, at the company's option. We reserve the right to inspect and/or require confirmation of installation method.

WHAT IS NOT COVERED BY THIS WARRANTY

Ordinary wear and tear shall not be considered a defect in workmanship or material. These warranties do not apply for loss or damage caused by accident, fire, abuse, misuse, improper use, modification, misapplication, failure to maintain the product as provide herein, or by any repairs other than those provided by our authorized Service Center. This warranty is non-transferable.

UNAUTHORIZED CHANNELS AND MISSING SERIAL NUMBERS

If a valid serial number is missing from the product, the warranty will be voided. Vollara products are for sale through authorized Vollara sales representatives. Warranties are voided if a product is purchased through unauthorized channels; this includes company sponsored or independent websites that are not authorized to use Vollara trademarked names, images and logos as well as Internet auction sites (e.g. eBay and Craigslist). The only approved Internet presence for Vollara products is vollara.com. To confirm warranty coverage prior to purchasing a product, please contact Customer Service at 800.989.2299 or email customerservice@vollara.com with the serial number located on the unit.

EXCLUSION OF OTHER WARRANTIES AND CONDITIONS

EXCEPT AS PROVIDED HEREIN, AND TO THE EXTENT CONSISTENT WITH APPLICABLE LAWS, WE MAKE NO REPRESENTATION OR WARRANTY OF ANY KIND. ALL OTHER WARRANTIES OF ANY KIND, EXPRESS OR IMPLIED, ARE HEREBY EXPRESSLY DISCLAIMED, INCLUDING ANY IMPLIED WARRANTY OF MERCHANTABILITY OR FITNESS FOR A PARTICULAR PURPOSE.

LIMITATION OF LIABILITY FOR SPECIAL, INCIDENTAL, OR CONSEQUENTIAL DAMAGES

TO THE EXTENT CONSISTENT WITH APPLICABLE LAWS, WE SHALL NOT IN ANY CASE BE LIABLE FOR SPECIAL, INCIDENTAL OR CONSEQUENTIAL DAMAGES ARISING FROM BREACH OF EXPRESSED OR IMPLIED WARRANTIES, CONDITIONS, GUARANTEES OR REPRESENTATIONS, BREACH OF CONTRACT, NEGLIGENCE OR ANY OTHER LEGAL THEORY.

Such excluded damages include, but are not limited to, loss of profits or revenue, and loss of the use of the products, and any loss caused by leaks or other water damage.

FOR U.S. APPLICATION ONLY

This warranty gives you specific legal rights, and you may also have other rights which vary from state to state. Some states do not allow limitations on warranties, or on remedies for breach. In such states, the above limitations may not apply to you.

This warranty is provided by:

Vollara, LLC
1300 Valley Drive
Bristol, VA 24201

SERVICE

Every effort is made to ensure customers receive an up-to-date owner's manual on the use of our products; however, from time to time, modifications to our products may without notice make the information contained herein subject to alteration. For the latest information, please view the owner's manual at vollara.com/manuals.

FCC Declaration & Responsible Party

This equipment has been tested and found to comply with the limits for a Class B digital device, pursuant of part 15 of the FCC Rules. These limits are designed to provide reasonable protection against harmful interference in a residential installation. This equipment generates, uses, and can radiate radio frequency energy, and if not installed and used in accordance with the instructions, may cause harmful interference to radio communications. However, there is no guarantee that interference will not occur in a particular installation. If this equipment does cause harmful interference to radio or television, which can be determined by turning the equipment off and on, the user is encouraged to try to correct the interference by one or more of the following measures:

- Reorient or relocate the receiving antenna.
- Increase the separation between the equipment and receiver.
- Connect the equipment into an outlet on a circuit different from that to which the receiver is connected.
- Consult the Independent Contractor for help.

FCC DECLARATION OF CONFORMITY

Name: Vollara® FreshAir Mobile

Model: A1018B

Produced for: Vollara, LLC

This device complies with Part 15 of the FCC Rules.

RESPONSIBLE PARTY

Vollara, LLC
1300 Valley Drive
Bristol, VA 24201

Ph: 800.989.2299

Signature:



Printed Name: Andrew Eide

Title: Chief Technology, Product & Regulatory Officer

Date: 03/25/2026

For information regarding the use of this product, please contact Customer Service at 800.989.2299 or email customerservice@vollara.com.

VOLLARA.COM

